

Worm Gear Hand Winches

Up to 4000 lb capacity

- **Machine Cut Worm Gears** provide accurate operation and long lasting service.
- **Enclosed Oil Bath** provides continuous lubrication of gears to minimize wear, except on Model 465. On Model 4WM2 oil seals keep oil in and dirt out.
- **Hex Drive** and handle are included. Model 4WM2 can be power driven with a maximum 400 rpm drill-motor.
- **Automatic Brake Models** provide positive load control for lifting. Brake models have a PB or B suffix. Model 4WM2 features an internal mechanical brake.
- **Corrosion Resistant** durable paint finish protects against corrosion in harsh environments.
- **Bronze Bearings** on most models for smooth operation.
- **Large Diameter Drums** minimize wire rope wear.
- **Handles Adjust** in length to change force required to move the load.
- **Mounting Options** include floor, wall, or ceiling. Adapter plate may be required, contact factory.
- **Two-year Limited Warranty**

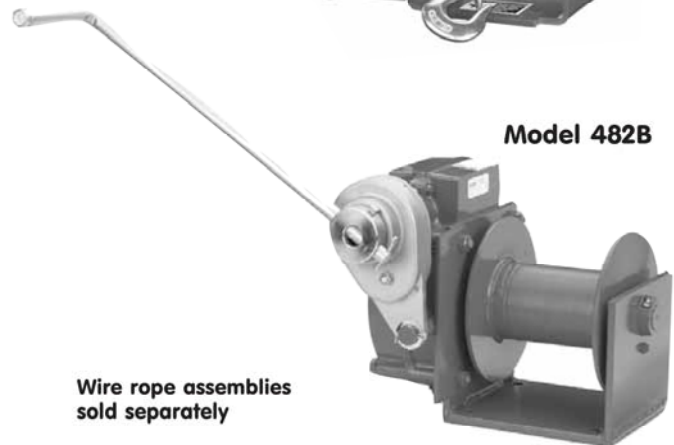
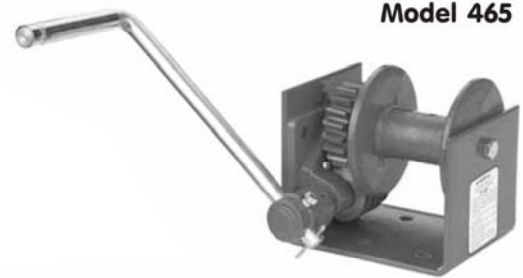

Wire rope assemblies sold separately

Worm Gear Hand Winches – Configurations and Performance Characteristics – Section 1

model number	description	load rating (lb)			wire rope dia. (in)	drum capacity (ft) ¹			gear ratio	force ² to lift 1000 lb	approx. ship wt. (lb)
		1st layer	mid drum	full drum		1st layer	mid drum	full drum			
465	750 lb – open gears (recommended for pulling only)	750	600	400	1/8 3/16	7 4	58 27	130 59	20:1	21 lb	12
462	1000 lb – enclosed gearing (recommended for pulling only)	1000	700	500	1/8 3/16	7 4	61 28	140 61	15:1	34 lb	15
4622PB	1000 lb – enclosed gearing with brake (for lifting)	1000	700	500	1/8 3/16	7 4	61 28	140 61	15:1	26 lb	21
472	2000 lb – enclosed gearing (recommended for pulling only)	2000	1700	1300	3/16 1/4 5/16	15 11 8	65 35 23	140 77 52	24:1	24 lb	32
4WM2	2000 lb – enclosed gearing with brake (for lifting) Drill Driveable	2000	1500	1200	1/4 3/16 (not recommended for this winch)	11	35	77	32:1	14 lb	41
482	4000 lb – enclosed gearing (recommended for pulling only)	4000	3300	2500	1/4 5/16 3/8	23 18 14	140 91 65	300 200 140	26:1	31 lb	100
482B	4000 lb – enclosed gearing with brake (for lifting)	4000	3300	2500	1/4 5/16 3/8	23 18 14	140 91 65	300 200 140	26:1	21 lb	113

Please contact factory or nearest Thern Distributor for firm fixed price and delivery.

¹ Actual drum capacities may be 25-30% less, due to nonuniform winding. Wire rope tension will also affect drum capacity.

² Approximate handle force required to lift 1000 lb with an empty drum, and maximum handle length.

See Dimensions on Next Page

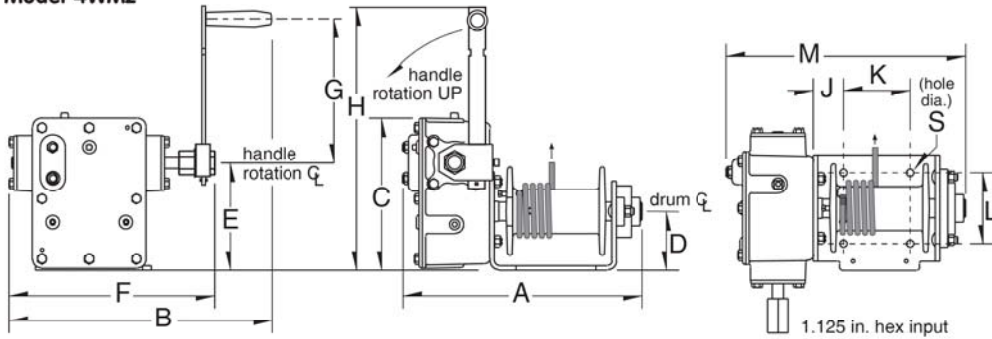
Model 4WM2

Install wire rope correctly as shown, or brake will not operate properly.

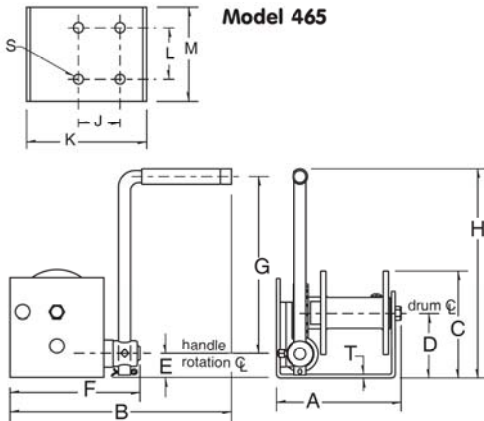
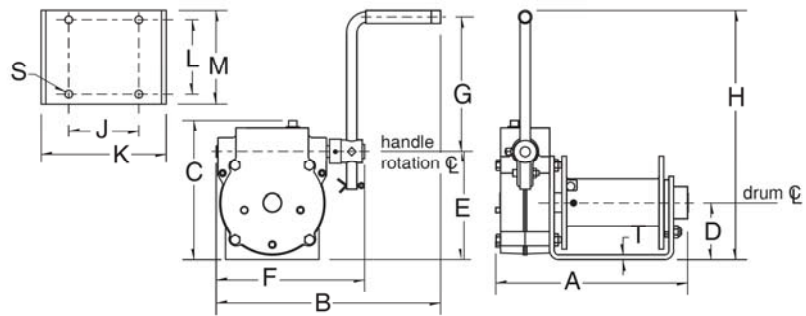
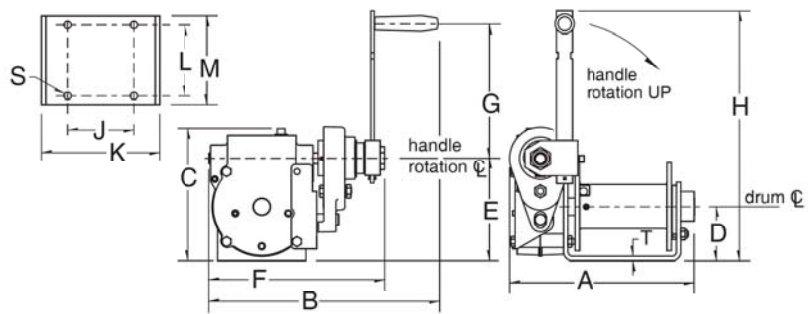
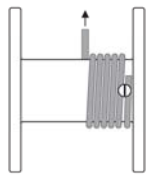
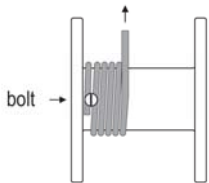
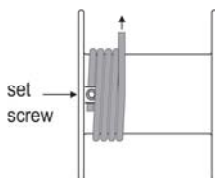
Model 465

Models 462, 472 and 482

Models 4622PB and 482B

Wire Rope Installation Model 465

Wire Rope Installation Models 462 and 4622PB

Wire Rope Installation Models 472, 482 and 482B

Worm Gear Hand Winches – Dimensions (in)

	465	462	4622PB	472	482	482B	4WM2
drum dia.	1.50	1.50	1.50	2.50	4.00	4.00	2.50
flange dia.	4.00	4.06	4.06	5.00	8.50	8.50	5.00
drum width	2.81	2.81	2.81	5.00	6.50	6.50	5.00
A	6.50	7.75	7.50	10.12	13.97	13.97	13.50
B	10.50	10.25	11.81	12.00	18.88	20.94	15.56
C	5.44	5.63	5.62	7.12	12.80	12.80	8.56
D	3.40	2.38	2.40	3.06	5.75	5.75	3.31
E	1.40	4.38	4.38	5.81	10.38	10.38	6.04
F	6.38	5.88	7.60	7.94	12.50	15.47	11.56
G	8.75	9.00	10.59	7.25	12.25	18.38	10.59
H	10.59	13.38	15.59	13.38	22.62	29.19	17.30
J	2.00	2.00	2.00	3.75	7.00	7.00	1.75
K	5.75	4.44	4.44	6.69	9.00	9.00	3.75
L	2.50	2.50	2.50	4.00	6.00	6.00	4.00
M	4.50	3.50	3.50	5.00	8.00	8.00	13.50
S (hole dia.)	.40	.40	.40	.40	.56	.56	.41
T	.19	.19	.19	.25	.50	.50	—

Dimensions are for reference only and subject to change without notice.

Important:

It is the owner's or operator's responsibility to determine the suitability of the equipment to its intended use. Study all applicable codes, manuals, and regulations. Be sure to read the Owner's Manual supplied with the equipment before operating it.